

VARVEL[®]
MOTION CONTROL SINCE 1955

technology made in Italy



IT
GB
DE



Bearings & Power Transmission Pty Ltd
(Phone) 07 4636 0522
Email: sales@bpt.net.au
(website) www.bpt.net.au

Dal 1955 Varvel progetta e realizza riduttori e variatori per applicazioni fisse di piccola e media potenza. Partner affidabile nella produzione e vendita di organi di trasmissione grazie a un elevato livello di servizio, offre anche soluzioni personalizzate operando nel rispetto dei valori dell'impresa socialmente responsabile. Modularità e flessibilità guidano la progettazione dei prodotti Varvel nella realizzazione di kit comuni a tutte le famiglie di riduttori, agevolando così l'attività di distributori e rivenditori che possono configurare in pochi minuti il prodotto richiesto dal singolo cliente.

Tecnologia Made in Italy



Technology Made in Italy

Since 1955 Varvel has been making speed reducers and variators for light industry applications. Reliable partner in power transmission equipment offers also customized solutions always according to a socially responsible company values. Modularity and flexibility lead Varvel products by a unique kit form, common to all gearbox series. This feature allows distributors an easier job to set up required products in few minutes.

Technologie Made in Italy

Seit 1955 plant und stellt Varvel Getriebe und Verstellgetriebe für feste Kleinleistungsanwendungen her. Dank dem hohen Dienstniveau ist Varvel ein zuverlässiger Partner für Herstellung und Verkauf von Getriebewerkteilen und bietet massgeschneiderte Lösungen an, in Verbindung mit sozialverträglicher Handlungsweise. Modularität und Flexibilität sind Kennzeichen für Varvel-Produkte. Die Firma produziert Teile, die sich für alle Getriebetypen eignen. Distributoren und Verkäufer können somit den Kundenanforderungen gerecht werden.





RIDUTTORI A VITE SENZA FINE E INGRANAGGI
per sistemi d'allevamento

WORM AND HELICAL SPEED REDUCERS
for agricultural application

SCHNECKEN- UND STIRNRADGETRIEBE
für Landwirtschaft und Tierhaltung



Riduttori - Gearboxes - Getriebe

Sistema modulare - Modular System - Modularesystem



Sistemi di gabbie
 Cage system
 Anlagen für die Käfighaltung



Sistemi per l'alimentazione avicola
 Poultry feeding systems
 Fütterungsanlagen für die Bodenhaltung

Trasportatori e raccolta uova
 Egg conveyors
 Eier Förder- und Sortieranlagen



VA
 technology

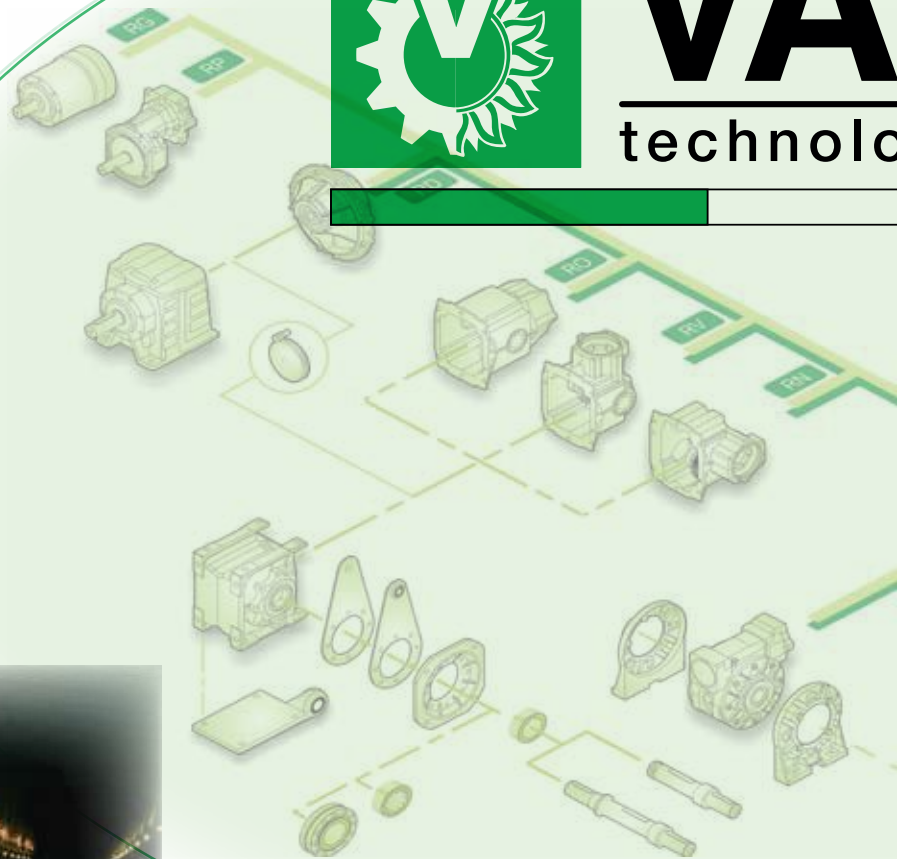

Getriebe - Gearboxes - Riduttori

Modularsystem - Modular System - Sistema modulare

Rfarm

Technology made in Italy



Raschiatori
 Scrapers
 Entmistungsanlage



Spazzole rotanti
 Cow Brushes
 Kuh Bürstenmaschinen



Sistemi per l'alimentazione suina
 Pig feeding systems
 Fütterungsanlagen für Schweine

Giunto elastico "G" - Elastic coupling "G" - Elastische Kupplung "G"

L'utilizzo del **giunto elastico "G"** in sostituzione al tradizionale accoppiamento albero/linguetta tra motore e riduttore, introduce molteplici vantaggi mantenendo invariato l'ingombro complessivo del riduttore stesso.

The introduction of **flexible coupling "G type"** as replacement of traditional shaft/key fitting between motor and gearbox, gives various advantages but keeping unchanged gearbox overall dimensions.

Die Einführung der **flexiblen Kupplung "G-Typ"** als Ersatz zur traditionellen Welle/Passfeder Montage zwischen Motor und Getriebe, hat verschiedene Vorteile, bei unveränderten Abmessungen des Getriebe.

Vantaggi

- Un solo riduttore per rapporto
- Maggiore flessibilità
- Rotazione stock aumentata
- Eliminazione dell'ossidazione per sfregamento (tribocorrosione)
- Gioco "zero" nel collegamento
- Disallineamento angolare 1° max
- Rigidità torsionale
- Smorzamento vibrazioni

Advantages

- One gearbox only for each ratio
- Greater flexibility
- Increased stock rotation
- Fretting corrosion elimination
- Coupling zero backlash
- Angular misalignment 1deg. max.
- Torsional rigidity
- Vibration damping

Vorzüge

- nur eine Getriebekomponente je Übersetzung
- gesteigerte Flexibilität
- höherer Lagerumschlag
- Vermeidung von Passungsrost
- spielfrei Verbindung
- Winkelausgleich bis 1°
- Verdrehsteifigkeit
- Dämpfung von Schwingungen

Anello elastico	Elastomero termoplastico
Spider	Thermoplastic elastomer
Kupplungsscheibe	Thermoplastic Elaste

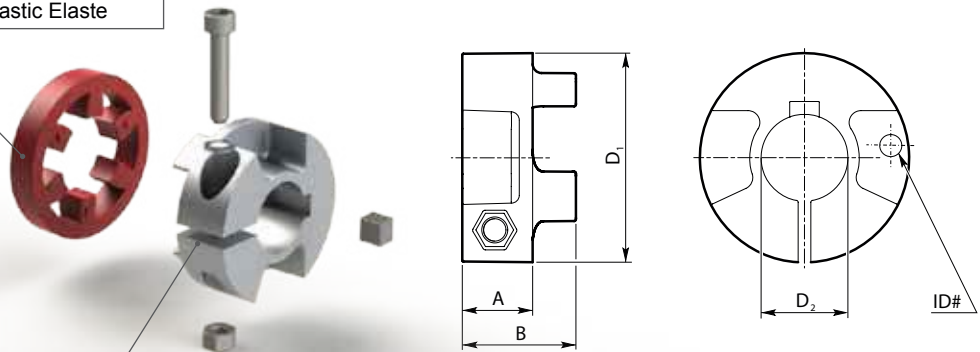

Semigiunto motore	Alluminio pressofuso (*Acciaio)
Motor half-coupling	Alu pressure die cast (*Steel)
Motorkupplungshäfte	Aluminium Druckguss (*Stahl)

Giunto Coupling Kupplung	IEC	Codice kit Kit code	RD	RS-RT	RP	M _t [Nm]	M _{t1} [Nm]	M _{t2} [Nm]	A [mm]	B [mm]	D ₁ [mm]	D ₂ [mm]	ID#
G3	IEC	KG3.009	03	28-40	---	4.5 - 6	15	8 - 10	11	19	30	9	309
		KG3.011	03	28-40	---	4.5 - 6	15	8 - 10			11	311	
		KG3.014	03	40	---	7 - 8.5	28	18 - 22			36	14	314
G5	IEC	KG5.009	02-12-13-23	---	---	8.9 - 10	14	8 - 10	14.5	23	45	9	509
		KG5.011	02-12-13-23	50-60	---		15	8 - 10			45	11	511
		KG5.014	02-12-13-23	50-60	90		30	12 - 17			45	14	514
		KG5.019	02-12-23	50-60	90		40	20 - 25			45	19	519
		KG5.024	12-23	60	90		70	30 - 40			52	24	524
G6	IEC	KG6.014	22-32-33-42-43	70	---	15.3 - 18	60	30 - 40	19.5	31.5	58	14	614
		KG6.019	22-32-33-42-43	70-85-110	---		90	50 - 65			19	619	
		KG6.024	22-32-33-42-43	70-85-110	---		130	85 - 100			24	624	
		KG6.028	22-32-42	70-85-110	---		180	100 - 120			28	628	
*GS8	IEC	* KGS8.19	52-53-62-63	---	---	15	150	---	35	51	79	19	819
		* KGS8.24	52-53-62-63	---	---		250	---			24	824	
		* KGS8.28	52-53-62-63	---	---		350	---			28	828	
		* KGS8.38	52-62-63	---	---		500	---			38	838	
		* KGS8.42	52-62	---	---		500	---			42	842	
		* KGS8.48	52-62	---	---		500	---			48	848	

Getriebe - Gearboxes - Riduttori RP

RP

**RIDUTTORI A INGRANAGGI A UNA COPPIA
SINGLE STAGE HELICAL GEARBOXES
EINSTUFIGE STIRNRADGETRIEBE**



Getriebe - Gearboxes - Riduttori RP

Technische Daten - Technical data - Dati tecnici

	P_1 [kW]	i_r	n_2 [rpm]	M_2 [Nm]	FS
1400 rpm / 50 Hz	0,25	2.52	556	4.2	8.3
		2.95	475	4.9	6.7
		3.2	438	5.3	6.2
		3.94	355	6.6	4.6
		4.25	329	7.1	4.1
		4.73	296	7.9	3.7
		5.07	276	8.5	3.3
		5.7	246	9.5	2.6
		7.0	200	11.7	2.0
	7.91	177	13.2	1.6	
	0,37	2.52	556	6.2	5.6
		2.95	475	7.3	4.5
		3.2	438	7.9	4.2
		3.94	355	9.7	3.1
		4.25	329	10.5	2.8
		4.73	296	11.7	2.5
		5.07	276	12.5	2.2
		5.7	246	14.1	1.8
		7.0	200	17.3	1.3
	7.91	177	19.6	1.1	
	0,55	2.52	556	9.3	3.8
		2.95	475	10.8	3.0
		3.2	438	11.8	2.8
		3.94	355	14.5	2.1
		4.25	329	15.6	1.9
		4.73	296	17.4	1.7
		5.07	276	18.6	1.5
		5.7	246	21.0	1.2
7.0		200	25.7	0.9	
0,75	2.52	556	12.6	2.8	
	2.95	475	14.8	2.3	
	3.2	438	16.0	2.1	
	3.94	355	19.8	1.5	
	4.25	329	21.3	1.3	
	4.73	296	23.7	1.2	
	5.07	276	25.4	1.1	
	5.7	246	28.6	0.9	
1,1	2.52	556	18.5	1.6	
	2.95	475	21.7	1.4	
	3.2	438	23.5	1.3	
	3.94	355	29.0	1.0	
	4.25	329	31.3	0.9	
	4.73	296	34.8	0.8	
	5.07	276	37.3	0.8	
	1,5	2.52	556	25.3	1.2
2.95		475	29.6	1.0	
3.2		438	32.1	0.8	

	P_1 [kW]	i_r	n_2 [rpm]	M_2 [Nm]	FS
1750 rpm / 60 Hz	0.25	2.52	694	3.4	10.4
		2.95	593	3.9	8.4
		3.2	547	4.3	7.8
		3.94	444	5.3	5.8
		4.25	412	5.7	5.1
		4.73	370	6.3	4.6
		5.07	345	6.8	4.1
		5.7	307	7.6	3.3
		7.0	250	9.4	2.5
	7.91	221	10.6	2.0	
	0.37	2.52	694	5.0	7.0
		2.95	593	5.8	5.6
		3.2	547	6.3	5.3
		3.94	444	7.8	3.9
		4.25	412	8.4	3.5
		4.73	370	9.4	3.1
		5.07	345	10.0	2.8
		5.7	307	11.3	2.3
		7.0	250	13.9	1.6
	7.91	221	15.7	1.4	
	0.55	2.52	694	7.4	4.8
		2.95	593	8.7	3.8
		3.2	547	9.4	3.5
		3.94	444	11.6	2.6
		4.25	412	12.5	2.4
		4.73	370	13.9	2.1
		5.07	345	14.9	1.9
		5.7	307	16.8	1.5
7.0		250	20.6	1.1	
7.91	221	23.3	1.0		
0.75	2.52	694	10.1	3.5	
	2.95	593	11.8	2.9	
	3.2	547	12.8	2.6	
	3.94	444	15.8	1.9	
	4.25	412	17.0	1.6	
	4.73	370	19.0	1.5	
	5.07	345	20.3	1.4	
	5.7	307	22.9	1.1	
	7.0	250	28.1	0.9	
7.91	221	31.7	0.8		
1.1	2.52	694	14.8	2.0	
	2.95	593	17.4	1.8	
	3.2	547	18.8	1.6	
	3.94	444	23.2	1.3	
	4.25	412	25.0	1.1	
	4.73	370	27.8	1.0	
	5.07	345	29.8	1.0	
	5.7	307	33.5	0.8	
1.5	2.52	694	20.2	1.5	
	2.95	593	23.7	1.3	
	3.2	547	25.7	1.0	
	3.94	444	31.6	0.8	

RP Riduttori - Gearboxes - Getriebe

Dimensioni - Dimensions - Abmessungen

Riduttori e flange di uscita - Gearboxes and output flange - Getriebe und Abtriebsflansche

FRP-G 90 B5

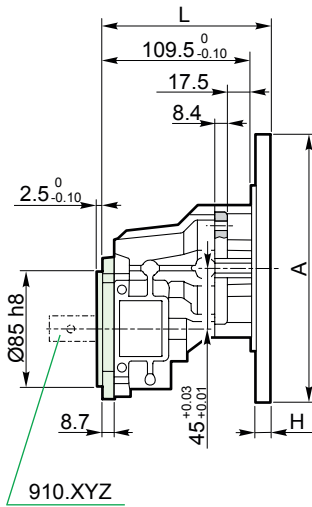

FRP-G 90 B5/1

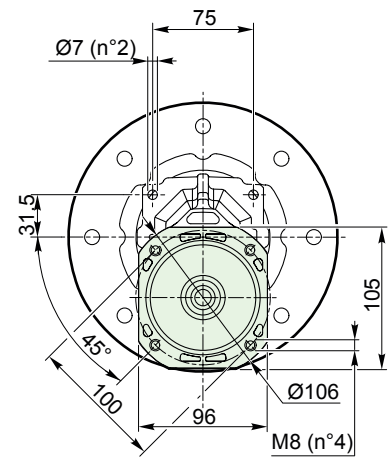
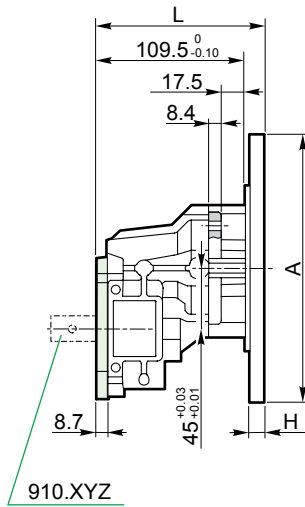

FRP-G 90 SQ

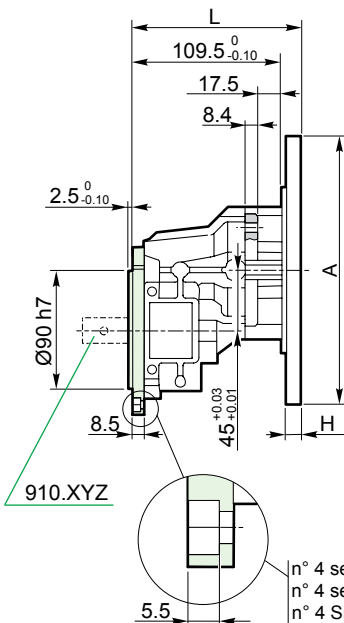

FRP-G 90 SQ/1

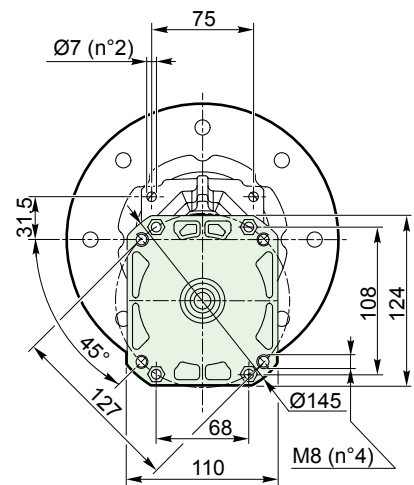
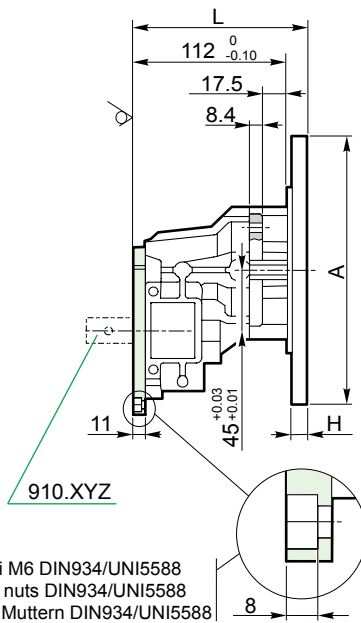

Getriebe - Gearboxes - Riduttori RP

Abmessungen - Dimensions - Dimensioni

FRP-G 90 B5/140

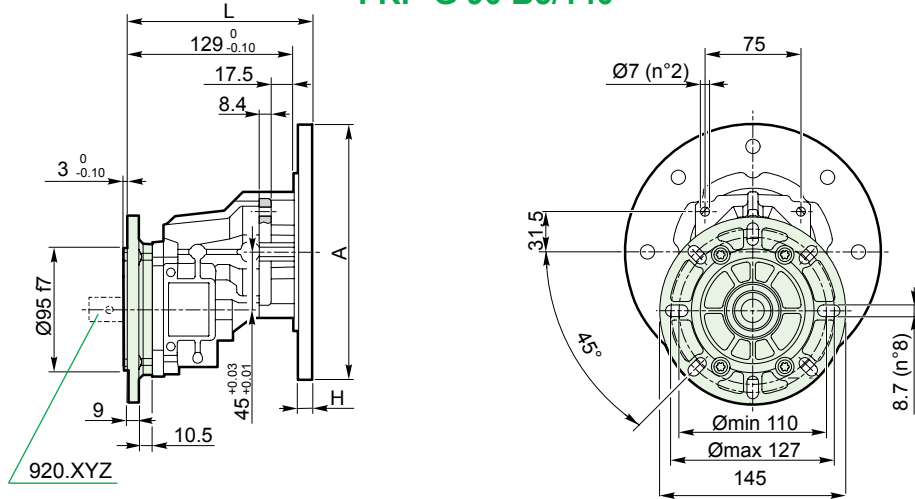

FRP-G 90 B5/160

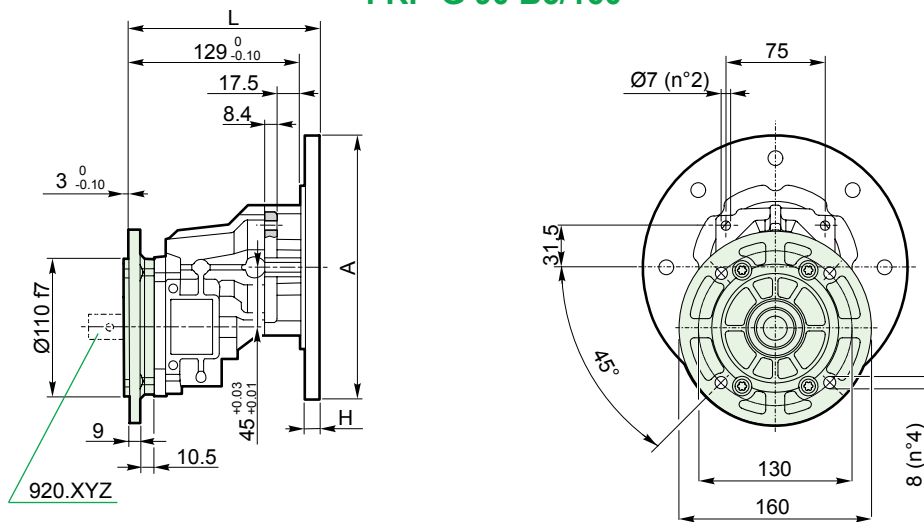

IEC Motorflanschen - IEC motor flanges - Flange motore IEC

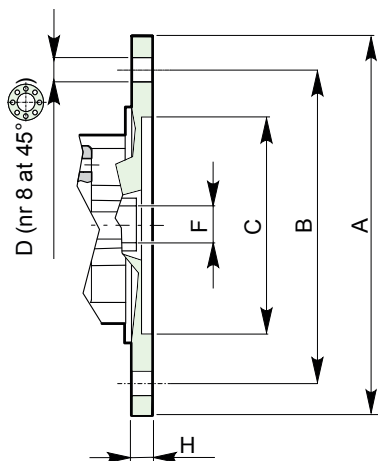

		71B5	71B14	80B5	80B14	90B5	90B14
	A	160	105	200	120	200	140
	B	130	85	165	100	165	115
	C	110	70	130	80	130	95
	D	10	7	11	7	11	10
	F	14	14	19	19	24	24
	H	11.5	10.5	11.5	10	11.5	11
FRP90 B5 FRP90 B5/1 FRP90 SQ	L	125	125	125	127	150	152
FRP90 SQ/1		127.5	127.5	127.5	129.5	152.5	154.5
FRP90 B5/140 FRP90 B5/160		144.5	144.5	144.5	146.5	169.5	171.5

RP Riduttori - Gearboxes - Getriebe

Dimensioni - Dimensions - Abmessungen

Alberi di uscita - Output shafts - Abtriebswellen

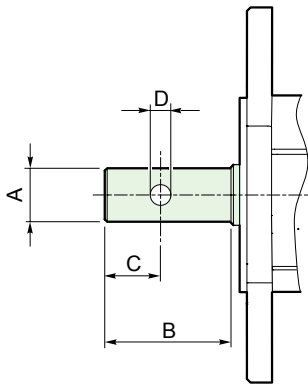

A	B	C	D (H11)	Codice albero Shaft ID Teilenummer Welle
ø16 ⁰ _{-0.05}	50	21	6.5	910.007
ø16 ⁰ _{-0.05}	50	21	7	910.018
ø18.8 ⁰ _{-0.1}	80	15	8.5	920.008
ø19 ⁰ _{-0.05}	57	23	6.5	910.001
ø19 ⁰ _{-0.05}	57	23	6.5	910.017
ø19 ^{h7}	40	14	6.5	920.006
ø19.7 ^{+0.05} _{-0.05}	100	50	6	920.016
ø20 ^{h7}	84	30	6	920.013
ø20 ⁰ _{-0.2}	52	23	6.5	920.022
ø21 ⁰ _{-0.1}	52	23	6	920.012
ø21 ⁰ _{-0.05}	57	23	6	910.024
ø22 ⁰ _{-0.1}	80	15	8.5	920.011
ø22 ⁰ _{-0.05}	57	23	8.5	910.004

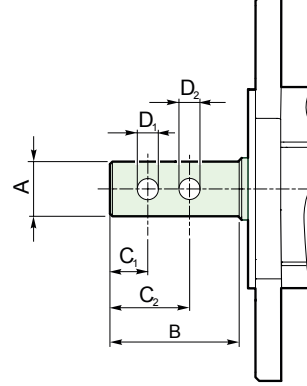

A	B	C ₁	C ₂	D ₁ (H11)	D ₂ (H11)	Codice albero Shaft ID Teilenummer Welle
ø19 ⁰ _{-0.05}	57	23	38	6.5	6.5	910.015
ø19 ⁰ _{-0.2}	92	30	48	8.5	8.5	910.002
ø19.7 ^{+0.05} _{-0.05}	100	30	50	6	6	910.014
ø20 ⁰ _{-0.05}	75	37	53	7	7	910.005
ø20 ^{h7}	72	20	40	8	6.5	920.023
ø22 ⁰ _{-0.2}	52	23	38	6.5	6.5	910.009

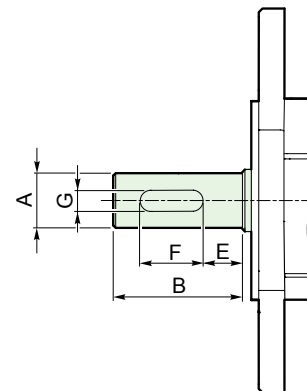

A	B	E	F	G	Codice albero Shaft ID Teilenummer Welle
					910.003
ø19 ^{h6}	40	5	30	6	910.019
					920.003

Nota: Selezione albero/flange uscita: vedere pag.

Note: Output shaft/flange selection: see pag.

Notiz: Notiz: Auswahl der Ausgangswellen und Flansche: s. Seite

Getriebe - Gearboxes - Riduttori RP

Abmessungen - Dimensions - Dimensioni

Abtriebsflansche - Output flanges - Flange di uscita

Codice albero Shaft ID Welle teilenummer	Flangia di uscita Output flange Abtriebsflansche				Quota di spallamento Shoulder value Schulter-Wert			
	B5 B5/1	SQ SQ/1	B5/140	B5/160	H ₁	H ₂	H ₃ *	H ₄ *
910.001	•	•			2.5		0	
910.002	•	•			0			2.5
910.003	•	•			0			2.5
920.003			•	•		9		
910.004	•	•			2.5		0	
910.005	•	•			2.5		0	
920.006			•	•		7.5		
910.007	•	•			3.5		1.0	
920.008			•	•		9		
910.009	•	•			4.5		2.0	
920.011			•	•		9		
920.012			•	•		9		
920.013			•	•	4.5			
910.014	•	•			4.5		2.0	
910.015	•	•			2.5		0	
920.016			•	•		9		
910.017	•	•			5.5		3.0	
910.018	•	•			3.5		1.0	
910.019	•	•			4.5		2.0	
920.022			•	•		9		
920.023			•	•	0			
910.024	•	•			2.5		0	

Altre estremità d'albero a richiesta - Other shaft ends on demand - weitere Ausgangswellen auf Anfrage

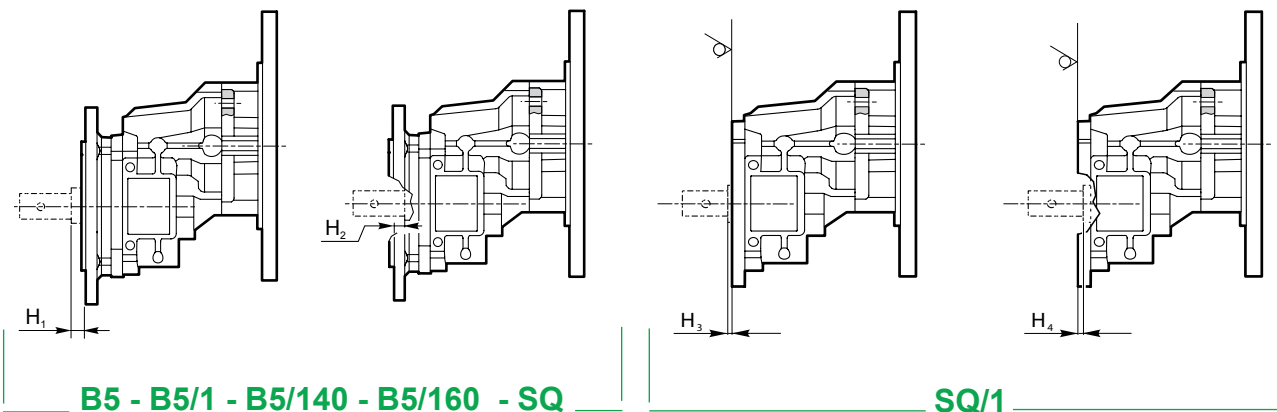

* Quota H₃ e H₄ solo per versioni con flange SQ/1 - Dimensions H₃ and H₄ for flange SQ/1 only - Abmessungen H₃ und H₄ nur Für Flansch SQ/1

Motori - Motors - Motoren

Designazione - Designation - Bezeichnungen

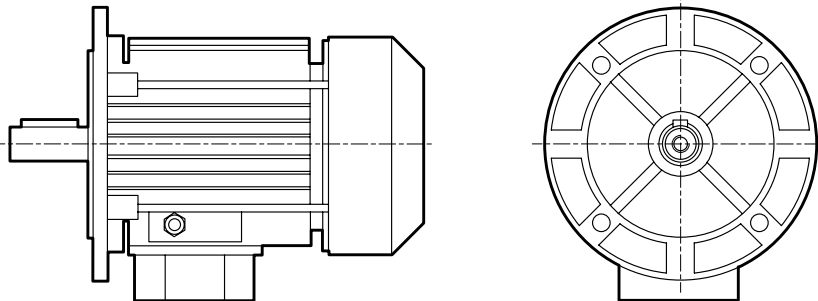

Motore - Motor - Motor RP - RD - RS - RT

MT	0.37 kW	71B	4	B14	230/400/50	IP55	F	X4
MT	0.06	56		B5				X1
MM		B14				X2
MA						X3
						X4
	15	160						

Posizione morsettiera - Terminal box position - Klemmkastenposition
 Classe d'isolamento - Insulation class - Isolationsklasse
 Class F (std)
 Grado di protezione - Protection class - Schutzart
 IP55 (std)
 Tensione/frequenza - Voltage/frequency - Spannung/Frequenz
 Forma costruttiva - Mounting format - Bauform
 Numero poli - Number of poles - Polzahl
 Grandezza IEC motore - IEC motor frame - IEC Motorbaugröße
 Potenza motore - Motor power - Motorleistung

MT = Motore trifase - Three-phase motor - Dreiphasenmotor
 MM = Motore monofase - Single-phase motor - Einphasenmotor
 MA = Motore autofrenante - Brake motor - Bremsmotor

Posizione morsettiera - Terminal position - Klemmenkastenlage position

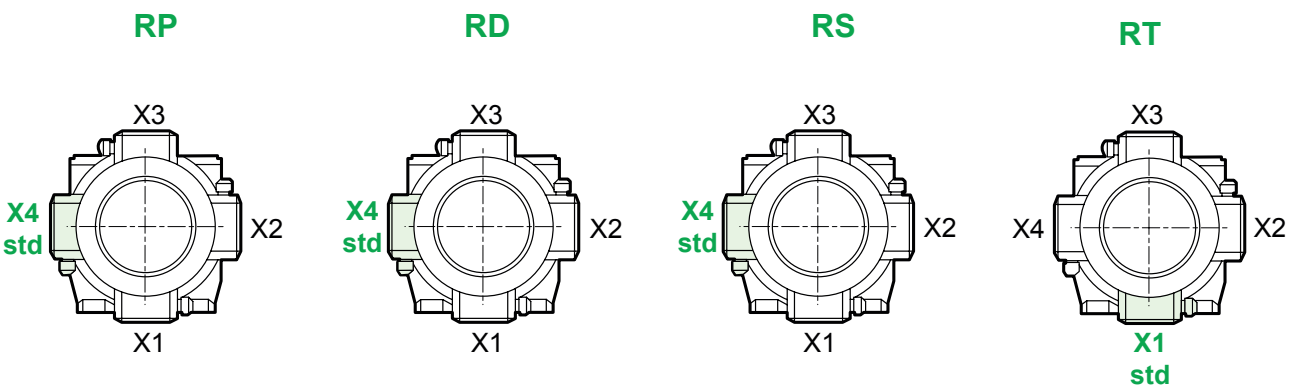

Getriebe - Gearboxes - Riduttori RD

RD

**RIDUTTORI A INGRANAGGI - DUE E TRE COPPIE
TWO AND THREE STAGE HELICAL GEARBOXES
ZWEI- UND DREISTUFIGE STIRNRADGETRIEBE**



RD Riduttori - Gearboxes - Getriebe

Dati tecnici - Technical data - Technische Daten

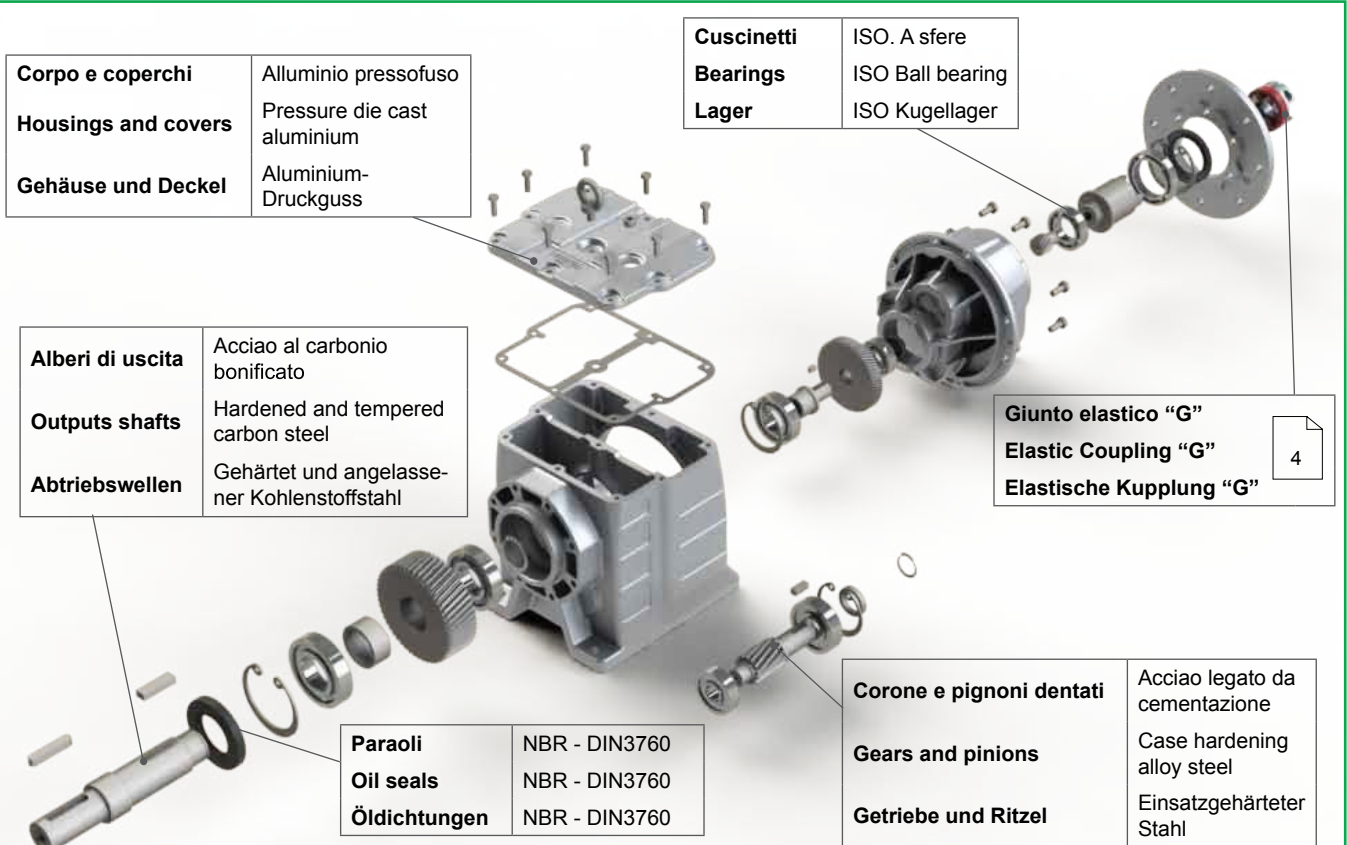

Designazione - Designation - Bezeichnungen

F	RD	3	2	/B3	H	6.3	IEC71	-B14	AU30	DFU200
M	RD	0	2	B3	H	2.25	56	B5		
F		1	3	B5	V	..	63	B14		
S		2				..	71			
..		3				..	80			
		4				..	90			
		5				630	100			
		6					112			
							132			

Flangia di uscita \varnothing - Output flange \varnothing - Ausgangsflansch \varnothing
 Albero di uscita \varnothing - Output shaft \varnothing - Ausgangswelle \varnothing
 Forma motore elettrico - Motor form - Motorbauform
 Grandezza IEC motore elettrico - IEC motor size - IEC Motorbaugröße
 Rapporto di riduzione - Reduction ratio - Getriebeübersetzung
 Forma di montaggio riduttore - Gearbox mounting position- Einbaulage des Getriebes
 Forma costruttiva riduttore - Gearbox form - Bauform des Getriebes
 Numero coppie di riduzione - Number of reduction stages - Anzahl der Getrebestufen
 Grandezza del riduttore - Gearbox size - Getriebegröße
 Tipo di riduttore - Gearbox type - Getriebetyp

M = Motoriduttore - Geared Motor - Getriebemotor
 F = Riduttore con flangia di entrata - Gearbox with input flange - Getriebe mit Eingangsflansch
 S = Riduttore senza flangia di entrata - Gearbox without input flange - Getriebe ohne Eingangsflansch
 .. = Riduttore con albero di entrata sporgente - Gearbox with input free shaft - Getriebe mit freie Eingangswelle

Getriebe - Gearboxes - Riduttori RD

$n_1 = 1400$ rpm

Technische Daten - Technical data - Dati tecnici

i_n	RD0			RD1			RD2			RD3		
	n_2 [rpm]	P_1 [kW]	M_2 [Nm]	n_2 [rpm]	P_1 [kW]	M_2 [Nm]	n_2 [rpm]	P_1 [kW]	M_2 [Nm]	n_2 [rpm]	P_1 [kW]	M_2 [Nm]
2.5	545	1.8	30	560	2.5	45	560	5.0	85	560	10.5	190
3.15	427	1.8	33	445	2.2	45	445	4.4	90	445	9.2	205
4.0	329	1.3	36	350	1.8	50	350	3.8	100	350	7.9	220
5.0	265	1.1	38	280	1.6	55	280	3.1	105	280	6.6	235
6.3	234	1.2	48	220	2.1	90	220	4.1	175	220	9.3	370
8.0	175	1.0	49	175	1.7	90	175	3.4	180	175	7.6	370
10.0	135	0.8	50	140	1.3	90	140	2.7	180	140	6.2	375
12.5	100	0.8	50	110	1.1	90	110	2.2	180	110	4.9	380
16.0	86	0.5	61	90	0.9	90	90	1.8	185	90	3.7	390
20.0	65	0.4	51	70	0.7	90	70	1.4	190	70	3.2	390
25.0	52	0.3	52	55	0.6	95	55	1.1	190	55	2.5	395
31.5	46	0.3	52	45	0.5	95	45	1.0	190	45	1.7	400
40	40	0.2	35	35	0.3	70	35	0.5	140	35	1.1	285
50	33	0.1	35	30	0.2	70	30	0.4	140	30	0.9	285
63	---	---	---	22	0.2	70	22	0.3	140	22	0.7	285
40	37	0.2	52	35	0.4	95	35	0.8	200	35	1.7	420
50	30	0.2	52	30	0.3	95	30	0.6	200	30	1.3	420
63	23	0.1	52	22	0.2	95	22	0.5	200	22	1.0	420
80	18	0.1	52	18	0.2	100	18	0.4	200	18	0.9	420
100	15	0.1	52	14	0.2	100	14	0.3	200	14	0.7	425
125	11	0.1	52	11	0.1	100	11	0.3	200	11	0.5	425
160	9	0.1	52	9	0.1	100	9	0.2	200	9	0.4	425
180	8	0.05	52	---	---	---	---	---	---	---	---	---
200	7	0.03	36	7	0.1	100	7	0.2	200	7	0.3	425
250	5.5	0.02	36	5.5	0.1	100	5.5	0.1	200	5.5	0.3	430
280	5	0.02	36	---	---	---	---	---	---	---	---	---
315	4.3	0.02	36	4.5	0.1	100	4.5	0.1	200	4.5	0.2	430
400	---	---	---	3.5	0.03	70	3.5	0.1	140	3.5	0.1	290
500	---	---	---	2.8	0.02	70	2.8	0.04	140	2.8	0.1	290
630	---	---	---	2.2	0.02	70	2.2	0.04	140	2.2	0.1	290

 due coppie di riduzione - two reductions stages - zwei Stufen

 tre coppie di riduzione - three reductions stages - drei Stufen

Rapporti fornibili a richiesta $i_n = 2.25 - 2.80 - 3.55 - 4.5 - 5.6 - 7.1 - 9.0$ tutte le grandezze, $i_n = 35.5$ solo per RD0

Ratios available on request $i_n = 2.25 - 2.80 - 3.55 - 4.5 - 5.6 - 7.1 - 9.0$ all sizes, $i_n = 35.5$ only RD0

Untersetzungen auf Anfrage $i_n = 2.25 - 2.80 - 3.55 - 4.5 - 5.6 - 7.1 - 9.0$ alle Größen, $i_n = 35.5$ nur RD0

RD Riduttori - Gearboxes - Getriebe

Dati tecnici - Technical data - Technische Daten

$n_1 = 1400$ rpm

i_n	RD4			RD5			RD6		
	n_2 [rpm]	P_1 [kW]	M_2 [Nm]	n_2 [rpm]	P_1 [kW]	M_2 [Nm]	n_2 [rpm]	P_1 [kW]	M_2 [Nm]
2.5	560	17.7	300	560	34	630	560	70	1300
3.15	445	15.3	320	445	30	690	445	60	1400
4.0	350	14.2	380	350	29	750	350	58	1600
5.0	280	12.3	400	280	26.8	850	280	55.4	1800
6.3	220	15.2	620	220	27.4	1160	220	46.8	2000
8.0	175	12.3	620	175	21.8	1170	175	36.6	2000
10.0	140	9.8	620	140	18.1	1180	140	31.7	2100
12.5	110	8	620	110	14.8	1190	110	25.7	2100
16.0	90	6.6	650	90	11.8	1200	90	20.3	2100
20.0	70	5.7	650	70	9.1	1220	70	15.5	2100
25.0	55	4.2	650	55	7.2	1230	55	13.0	2100
31.5	45	3.5	650	45	6.0	1240	45	10.0	2220
40	35	1.5	450	35	3.2	850	35	6	1600
50	30	1.2	450	30	2.4	850	30	4.9	1600
63	22	1.1	450	22	1.9	850	22	4.3	1600
40	35	2.5	700	35	5.0	1270	35	8.6	2200
50	30	2.1	700	30	4.1	1280	30	7	2200
63	22	1.5	700	22	3.4	1290	22	5.5	2200
80	18	1.7	700	18	2.6	1300	18	4.4	2300
100	14	1.1	700	14	2.1	1300	14	3.7	2300
125	11	0.9	700	11	1.6	1300	11	3.4	2300
160	9	0.7	700	9	1.3	1300	9	2.8	2300
180	---	---	---	---	---	---	---	---	---
200	7	0.6	700	7	1.1	1300	7	1.8	2300
250	5.5	0.4	700	5.5	0.8	1300	5.5	1.4	2300
280	---	---	---	---	---	---	---	---	---
315	4.5	0.35	700	4.5	0.45	900	4.5	1.1	2300
400	3.5	0.22	460	3.5	0.35	900	3.5	1.6	2300
500	2.8	0.12	460	2.8	0.3	900	2.8	0.8	2300
630	2.2	0.11	460	2.2	0.25	900	2.2	0.7	2300

due coppie di riduzione - two reductions stages - zwei Stufen

tre coppie di riduzione - three reductions stages - drei Stufen

Rapporti fornibili a richiesta $i_n = 2.25 - 2.80 - 3.55 - 4.5 - 5.6 - 7.1 - 9.0$ tutte le grandezze, $i_n = 35.5$ solo per RD0

Ratios available on request $i_n = 2.25 - 2.80 - 3.55 - 4.5 - 5.6 - 7.1 - 9.0$ all sizes, $i_n = 35.5$ only RD0

Untersetzungen auf Anfrage $i_n = 2.25 - 2.80 - 3.55 - 4.5 - 5.6 - 7.1 - 9.0$ alle Größen, $i_n = 35.5$ nur RD0

Getriebe - Gearboxes - Riduttori RD

Abmessungen - Dimensions - Dimensioni

B3

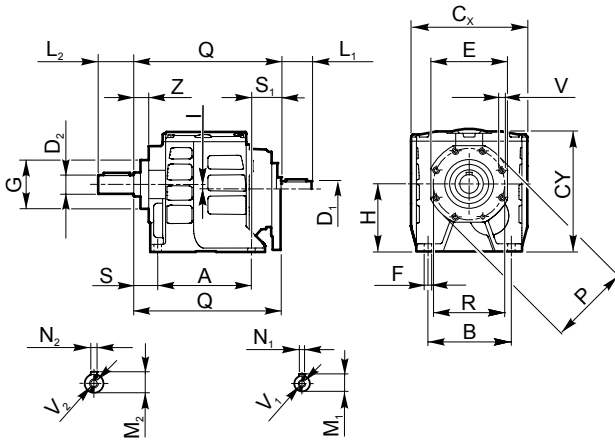

B5

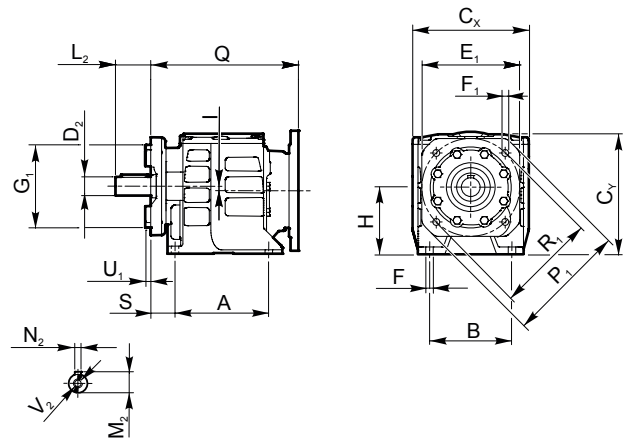

	RD02	RD03	RD12	RD13	RD22	RD23	RD32	RD33
A	95		110		130		165	
B	80		110		110		135	
C_x	100		140		155		190	
C_y	111		131		158		198	
D₁ h6	11		14		19		24	
D₂ h6	17 - 20		20 - 25		25 - 30		30 - 35	
E	82		82		102		125	
E₁	100 (115) [130]		100 (115) [130]		115 (130) [165]		130 (165) [215]	
F	9		9		9		11.5	
F₁	7 (9) [9]		7 (9) [9]		9 (9) [11]		9 (11) [13]	
G g6	60		60		65		85	
G₁ h7	80 (95) [110]		80 (95) [110]		95 (110) [130]		110 (130) [180]	
H	60		75		90		115	
I	4,5		5		6		8.5	
L₁	23		30		40		50	
L₂	35 (40)		40 (50)		50 (60)		60 (70)	
M₁	12.5		16		21.5		27	
M₂	19 - 22.5		22.5 - 28		28 - 33		33 - 38	
N₁	4		5		6		8	
N₂	5 - 6		6 - 8		8 - 8		8 - 10	
P	84		84		108		130	
P₁	120 (140) [160]		120 (140) [160]		140 (160) [200]		160 (200) [250]	
Q	140	143	151	161	190	208	220	253
R	75		75		95		115	
R₁	100 (115) [130]		100 (115) [130]		115 (130) [165]		130 (165) [215]	
S	20		18		25		30	
S₁	25	28	23	33	35	53	25	58
U₁	3 (3) [3]		3 (3) [3]		3 (3) [3]		3.5 (3.5) [3.5]	
V	M6x14 (n° 7)		M6x14 (n° 7)		M6x10 (n° 8)		M8x18 (n° 8)	
V₁	M5x12		M5x12		M6x16		M8x19	
V₂	M6x16 - M6x16		M6x16 - M6x16		M6x16 - M10x22		M10x22 - M10x22	
Z	13		10		13		13	
Kg	3.0	3.2	4.8	4.8	7.9	8.5	13.5	14.5

RD Riduttori - Gearboxes - Getriebe

Dimensioni - Dimensions - Abmessungen

B3

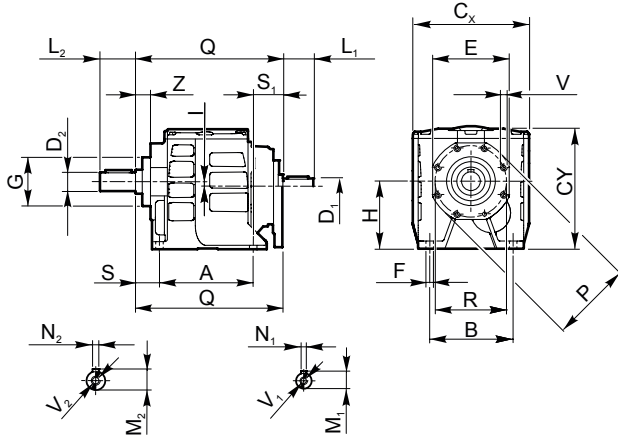

B5

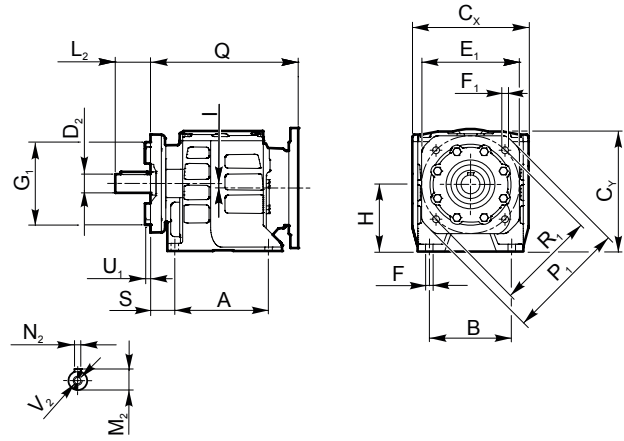

	RD42	RD43	RD52	RD53	RD62	RD63
A	195		205		260	
B	150		170		215	
C_x	215		284		340	
C_y	222		255		302	
D₁ h6	28		38		48	
D₂ h6	35 - 40		40 - 50		50 - 60	
E	142		180		180	
E₁	165 (215) [265]		215 (265) [300]		215 (265) [300]	
F	13.5		18		18	
F₁	11 (13.5) [17]		13.5 (17.5) [17.5]		13.5 (17.5) [17.5]	
G g6	95		130		130	
G₁ h7	130 (180) [230]		180 (230) [250]		180 (230) [250]	
H	130		140		180	
I	13.5		0		0	
L₁	60		80		100	
L₂	70 (80)		80 (100)		100 (120)	
M₁	31		41		51.5	
M₂	38 - 43		43 - 53.5		53.5 - 64	
N₁	8		10		14	
N₂	10 - 12		12 - 14		14 - 18	
P	145		190		190	
P₁	200 (250) [300]		250 (300) [350]		250 (300) [350]	
Q	265	305	353 [367]		410 [424]	
R	130		165		165	
R₁	165 (215) [265]		215 (265) [300]		215 (265) [300]	
S	30		35 [49]		40 (54)	
S₁	40	80	82		79	
U₁	4 (4) [4]		4 (4) [4]		4 (4) [4]	
V	M8x18 (n° 8)		M10x25 (n° 8)		M10x25 (n° 8)	
V₁	M10x22		M12x28		M16x36	
V₂	M10x22 - M12x28		M12x28 - M16x36		M16x36 - M20x42	
Z	15		18		18	
kg	20	21.5	49	52	62	70

Getriebe - Gearboxes - Riduttori RS-RT

RS-RT

**RIDUTTORI A VITE SENZA FINE
WORM GEARBOXES
SCHNECKENGETRIEBE**



RS-RT Riduttori - Gearboxes - Getriebe

Dati tecnici - Technical data - Technische Daten

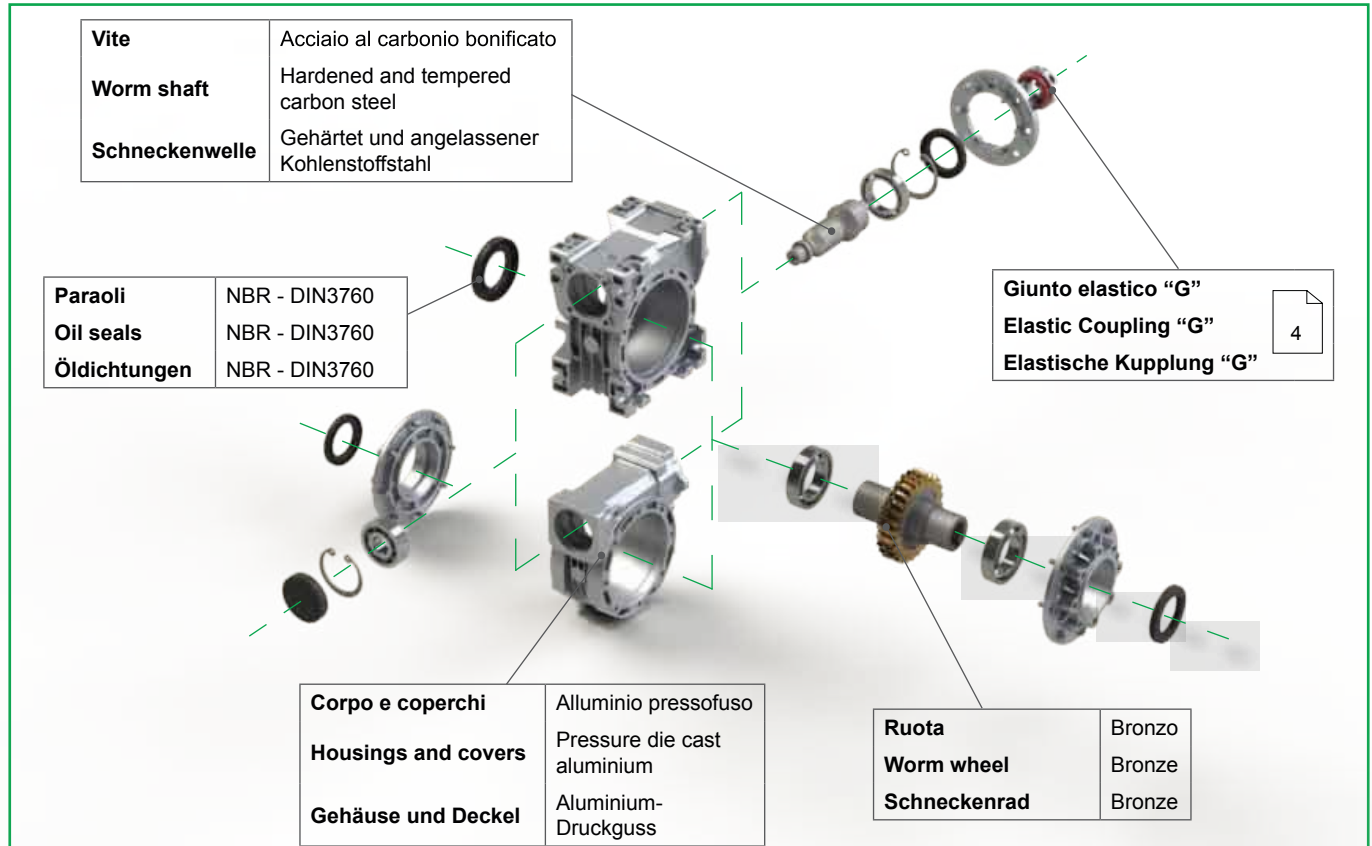

Designazione - Designation - Bezeichnungen

F	RS-G	..	/ 40	PC	28	IEC71	B14
M	RS-G	63	28	28	S	5	B5
F	RA	71	40	40	I	..	B14
S	RS/RS-G	80	50	50	D	..	
..	RT-G	100	60	60	PC	..	
	TA		70	70	FL	10000	
	RT/RT-G			85	B3		
				110	F		
				130			
				150			

Forma motore elettrico - Motor form - Motorbauform

Grandezza IEC motore elettrico - IEC motor size - IEC Motorbaugröße

Rapporto di riduzione - Reduction ratio - Getriebeübersetzung

Forma costruttiva riduttore - Gearbox form - Bauform des Getriebes

Grandezza del riduttore - Gearbox size - Getriebegröße

Grandezza 1° riduttore (combinati) - 1st gearbox size (combined) - Baugröße der 1. Getriebestufe (Doppelschnecke)

Grandezza precoppia - Helical stage size - Baugröße der Stirnradvorstufe

Tipo di riduttore - Gearbox type - Getriebetyp

M = Motorriduttore - Geared Motor - Getriebemotor

F = Riduttore con flangia di entrata - Gearbox with input flange - Getriebe mit Eingangsflansch

S = Riduttore senza flangia di entrata - Gearbox without input flange - Getriebe ohne Eingangsflansch

.. = Riduttore con albero di entrata sporgente - Gearbox with input free shaft - Getriebe mit freie Eingangswelle

Getriebe - Gearboxes - Riduttori RS-RT

$n_1 = 1400$ rpm

Technische Daten - Technical data - Dati tecnici

P_1 [kW]	Tipo riduttore Gearbox type Getriebe Typ	i_n	n_2 [rpm]	M_2 [Nm]
0.06	RS-RT 28	7	200	2.4
	RS-RT 28	10	140	3.3
	RS-RT 28	15	93	4.7
	RS-RT 28	20	70	6.1
	RS-RT 28	28	50	7.6
	RS-RT 28	40	35	10
	RS-RT 28	49	29	11
	RS-RT 28	56	25	12
	RS-RT 28	70	20	13
	RS-RT 40	80	18	16
	RS-RT 40	100	14	19
0.09	RS-RT 28	7	200	3.6
	RS-RT 28	10	140	5.0
	RS-RT 28	15	93	7.1
	RS-RT 28	20	70	9.1
	RS-RT 28	28	50	11
	RS-RT 28	40	35	15
	RS-RT 28	49	29	17
	RS-RT 40	56	25	20
	RS-RT 40	70	20	22
	RS-RT 40	80	18	25
	RS-RT 40	100	14	28
0.12	RS-RT 28	7	200	4.8
	RS-RT 28	10	140	6.6
	RS-RT 28	15	93	9.5
	RS-RT 28	20	70	12
	RS-RT 28	28	50	15
	RS-RT 40	40	35	20
	RS-RT 40	49	29	23
	RS-RT 40	56	25	26
	RS-RT 40	70	20	30
	RS-RT 40	80	18	33
	RS-RT 50	100	14	38
0.18	RS-RT 28	7	200	7.2
	RS-RT 28	10	140	9.9
	RS-RT 28	15	93	14
	RS-RT 40	20	70	18
	RS-RT 40	28	50	23
	RS-RT 40	40	35	30
	RS-RT 40	49	29	35
	RS-RT 40	56	25	39
	RS-RT 50	70	20	46
	RS-RT 50	80	18	51
	RS-RT 50	100	14	43

P_1 [kW]	Tipo riduttore Gearbox type Getriebe Typ	i_n	n_2 [rpm]	M_2 [Nm]
0.25	RS-RT 40	5	280	7.5
	RS-RT 40	7	200	10
	RS-RT 40	10	140	14
	RS-RT 40	15	93	20
	RS-RT 40	20	70	26
	RS-RT 40	28	50	32
	RS-RT 40	40	35	42
	RS-RT 50	49	29	52
	RS-RT 50	56	25	57
	RS-RT 50	70	20	63
	RS-RT 60	80	18	72
RS-RT 60	100	14	88	
0.37	RS-RT 40	5	280	11
	RS-RT 40	7	200	15
	RS-RT 40	10	140	21
	RS-RT 40	15	93	30
	RS-RT 40	20	70	38
	RS-RT 40	28	50	48
	RS-RT 50	40	35	65
	RS-RT 50	49	29	77
	RS-RT 60	56	25	85
	RS-RT 60	70	20	97
	RS-RT 60	80	18	107
RS-RT 60	100	14	130	
0.55	RS-RT 40	5	280	16
	RS-RT 50	7	200	23
	RS-RT 50	10	140	32
	RS-RT 50	15	93	44
	RS-RT 50	20	70	57
	RS-RT 50	28	50	75
	RS-RT 60	40	35	99
	RS-RT 60	49	29	114
	RS-RT 60	56	25	126
	RS-RT 70	70	20	155
	RS-RT 70	80	18	168
RS-RT 85	100	14	210	
0.75	RS-RT 50	5	280	23
	RS-RT 50	7	200	31
	RS-RT 50	10	140	43
	RS-RT 50	15	93	60
	RS-RT 60	20	70	79
	RS-RT 60	28	50	102
	RS-RT 60	40	35	135
	RS-RT 60	49	29	168
	RS-RT 70	70	20	210
	RS-RT 70	80	18	230
	RS-RT 70	100	14	280

RS-RT Riduttori - Gearboxes - Getriebe

Dati tecnici - Technical data - Technische Daten

$n_1 = 1400$ rpm

P_1 [kW]	Tipo riduttore Gearbox type Getriebe Typ	i_n	n_2 [rpm]	M_2 [Nm]
0.75	RS-RT 70	56	25	183
	RS-RT 85	70	20	226
	RS-RT 85	80	18	246
1.1	RS-RT 60	5	280	34
	RS-RT 60	7	200	45
	RS-RT 60	10	140	63
	RS-RT 60	15	93	91
	RS-RT 70	20	70	116
	RS-RT 70	28	50	158
	RS-RT 70	40	35	213
	RS-RT 85	49	29	246
	RS-RT 85	56	25	286
	RS-RT 110	70	20	352
	RS-RT 110	80	18	396
	RS-RT 110	100	14	458
	1.5	RS-RT 60	5	280
RS-RT 60		7	200	62
RS-RT 60		10	140	86
RS-RT 60		15	93	124
RS-RT 70		20	70	166
RS-RT 70		28	50	215
RS-RT 85		40	35	295
RS-RT 85		49	29	336
RS-RT 110		49	29	356
RS-RT 110		56	25	401
RS-RT 110		70	20	480
RS-RT 110		80	18	540
RS-RT 110		100	14	624
2.2	RS-RT 70	5	280	92
	RS-RT 70	7	200	92
	RS-RT 70	10	140	129
	RS-RT 70	15	93	187
	RS-RT 85	20	70	246
	RS-RT 85	28	50	319
	RS-RT 110	40	35	438
	RS-RT 110	49	29	522
	RS-RT 110	56	25	588
	RS-RT 110	70	20	704
	RS 130	80	18	756
	RS 150	100	14	945
	3.0	RS-RT 70	5	280
RS-RT 70		7	200	126
RS-RT 70		10	140	176
RS-RT 85		15	93	255

P_1 [kW]	Tipo riduttore Gearbox type Getriebe Typ	i_n	n_2 [rpm]	M_2 [Nm]
3.0	RS-RT 85	20	70	336
	RS-RT 110	28	50	435
	RS-RT 110	40	35	598
	RS-RT 110	49	29	712
	RS 130	49	29	722
	RS 130	56	25	814
	RS 150	70	20	974
	RS 150	80	18	1064
	RS 150	100	14	1289
4.0	RS-RT 85	5	280	122
	RS-RT 85	7	200	168
	RS-RT 85	10	140	235
	RS-RT 110	15	93	344
	RS-RT 110	20	70	453
	RS-RT 110	28	50	581
	RS 130	40	35	829
	RS 130	49	29	963
	RS 150	56	25	1085
5.5	RS-RT 110	56	25	1115
	RS 150	70	20	1299
	RS-RT 110	7	200	231
	RS-RT 110	10	140	326
	RS-RT 110	15	93	473
	RS-RT 110	20	70	623
	RS 130	28	50	809
	RS 130	40	35	1141
	RS 150	49	29	1342
7.5	RS 150	56	25	1534
	RS-RT 110	7	200	315
	RS-RT 110	10	140	445
	RS-RT 110	15	93	645
	RS 130	15	93	652
	RS 130	20	70	860
	RS 130	28	50	1103
	RS 150	40	35	1576
	11.0	RS 150	7	200
RS 150		10	140	660
RS 150		15	93	968
RS 150		20	70	1261
15.0	RS 150	7	200	637
	RS 150	10	140	900
	RS 150	15	93	1320

Getriebe - Gearboxes - Riduttori RS-RT

Abmessungen - Dimensions - Dimensioni

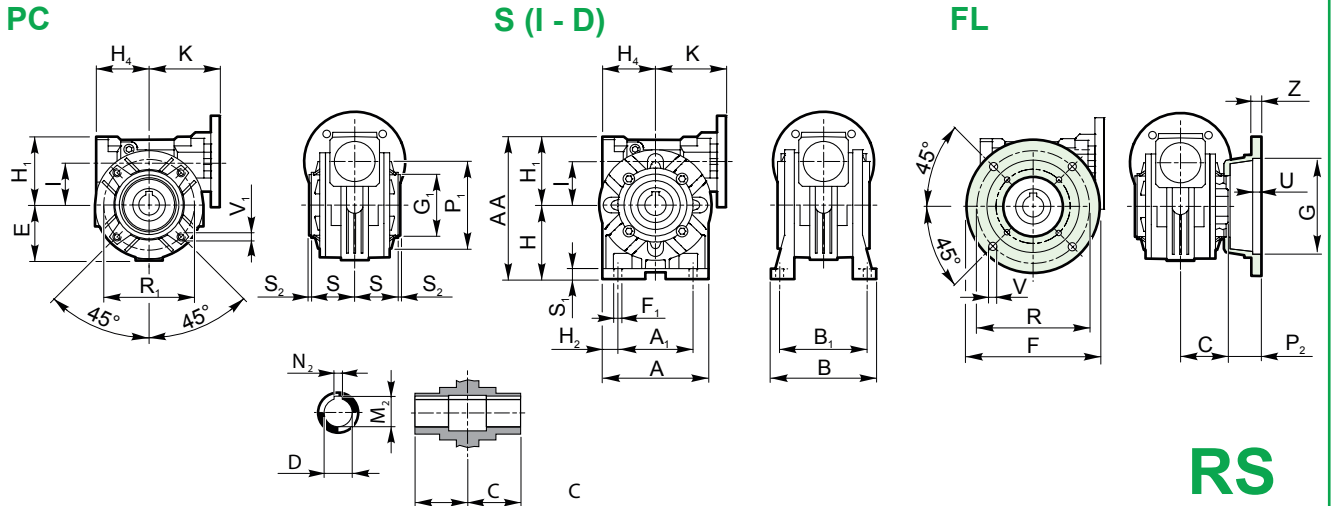

RS

	RS28	RS40	RS50	RS60	RS70	RS85	RS110	RS130	RS150
A	70	100	120	138	158	193	250	286	336
A₁	52	70	85	95	120	140	200	235	260
AA	99	138	163	192	221	252	333	400	454
B	78	102	119	136	140	168	200	230	250
B	66	84	99	111	116	140	162	190	210
C	30	41	49	60	60	61	77.5	90	105
D H7	14	19 - 18	24 - 25	25	28 - 30	32 - 35	42	48	55
E	34	50	61	70	80	98	125	143	168
F	70	140	160	180	200	200	250	300	350
F₁	5.5	7	9	11	11	13	14	15	19
G H8	40	95	110	115	130	130	180	230	250
G₁ H8	42	60	70	70	80	110	130	180	180
H	52	71	85	100	115	135	172	200	230
H₁	47	67	78	92	106	117	161	200	224
H₂	9	15	17.5	21.5	19	26.5	25	25.5	38
H₄	40	50	60	72	86	103	139	159	183
I	28	40	50	60	70	85	110	130	150
K	57.5	70.5	83 - 88*	93 - 94*	117 - 118*	134 - 137*	151 - 153*	165 - 166*	191 - 211*
M₂	16.3	21.8 - 20.8	27.3 - 28.3	28.3	31.3 - 33.3	35.3 - 38.3	45.3	51.8	59.3
N₂	5	6 - 6	8 - 8	8	8 - 8	10 - 10	12	14	16
P	49	82	91.5	116	111	100	150	150	160
P₁	67	94	100	102	118	150	200	234	250
P₂	19	41	42.5	56	51	39	72.5	60	55
R	56	115	130	150	165	165	215	265	300
R₁	56	83	85	85	100	130	165	215	215
S	32	38	49	57.5	57	56.5	74.5	87	102
S₁	6	9	12	12	14	15	17	19	20
S₂	3	2	2.5	2.5	3	3	2.5	5	5
U	4	6	10	10	12	6	5	5	6
V	6.5 (n°4)	9 (n°4)	9 (n°4)	11 (n°4)	13 (n°4)	13 (n°4)	15 (n°8)	15 (n°8)	19 (n°8)
V₁	M6x6 (n°4)	M6x9 (n°4)	M8x12 (n°4)	M8x15 (n°8)	M8x18 (n°8)	M10x20 (n°8)	M12x21 (n°8)	M12x24 (n°8)	M14x30 (n°8)
Z	6	10	10	11	14	14	16	18	20
kg	1.1	2.5	3.8	6.5	9	13.5	39	50	80

* - IEC71-B14 (RS50 - RS60) - IEC80-B14 (RS70) - IEC90-B14 (RS85) - IEC100/112-B14 (RS110 - RS130 - RS150)

RS-RT Riduttori - Gearboxes - Getriebe

Dimensioni - Dimensions - Abmessungen

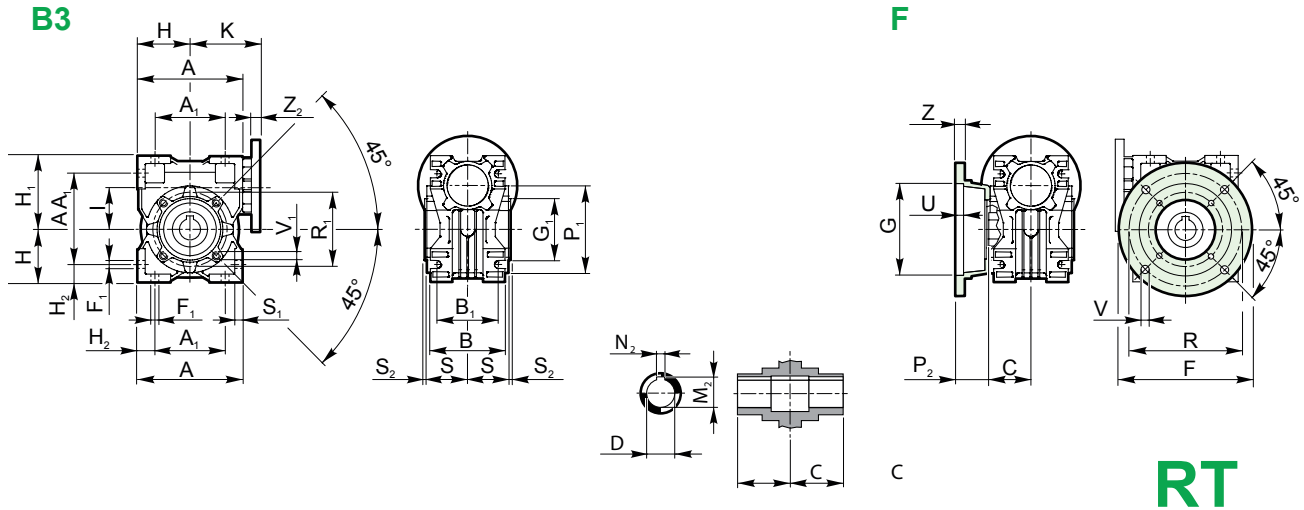

	RT28	RT40	RT50	RT60	RT70	RT85	RT110
A	80	100	120	144	172	206	255
A₁	54	70	80	100	120	140	170
AA	97	121.5	144	174	205	238	295
AA₁	71	91.5	104	130	153	172	210
B	53	71	85	100	112	130	144
B₁	44	60	70	85	90	100	115
C	30	41	49	60	60	61	77.5
D H7	14	19 - 18	24 - 25	25	28 - 30	32 - 35	42
F	80	110	125	180	200	210	270
F₁	7	7	9	9	11	13	15
G H8	50	60	70	115	130	152	170
G₁ H8	55	60	70	80	95	110	130
H	40	50	60	72	86	103	127.5
H₁	57	71.5	84	102	119	135	167.5
H₂	13	15	20	22	26	33	42.5
I	28	40	50	60	70	85	110
K	57.5	70.5	83 - 88*	93 - 94*	117 - 118*	134 - 137*	151 - 153*
M₂	16.3	21.8 - 20.8	27.3 - 28.3	28.3	31.3 - 33.3	35.3 - 38.3	45.3
N₂	5	6 - 6	8 - 8	8	8 - 8	10 - 10	12
P	53	69	93	86	111	111	131
P₁	75	86	100	110	130	160	200
P₂	23	28	44	25	51	50	53.5
R	68	87	90	150.5	165	175	230
R₁	65	75	85	95	115	130	165
S	27.5	38.5	46.5	57	57	67	74
S₁	6	7	8	10	11	14	13
S₂	2.5	2.5	3	3	3	3	3.5
U	10	4	5	6.5	12	6	5
V	7 (n° 4)	9 (n° 4)	11 (n° 4)	11 (n° 4)	13 (n° 4)	13 (n° 4)	14 (n° 8)
V₁	M6x10 (n° 4)	M6x8.5 (n° 4)	M8x10 (n° 4)	M8x20 (n° 8)	M8x16 (n° 8)	M10x18 (n° 8)	M10x21 (n° 8)
Z	7	6	10	10	14	16	18
Z₂	13	13	13	14 - 15	15.5 - 17.5	15.5 - 18.5	18 - 20
Kg	1.1	2.5	3.8	6.5	9	13.5	39

* - IEC71-B14 (RT50 - RT60) - IEC80-B14 (RT7) - IEC90-B14 (RT85) - IEC100/112-B14 (RT110)

Per rafforzare il proprio impegno nella società, dal 2004 Varvel ha iniziato un programma di sostegno continuativo di 3 associazioni onlus: UNICEF (Fondo delle Nazioni Unite per l'Infanzia), MSF (Medici Senza Frontiere) e ANT (Associazione Nazionale Tumori). Anche il rispetto e la tutela dell'ambiente fanno parte dei valori Varvel ed è per questo che dal 2001 Varvel ha certificato il Sistema Ambientale secondo la norma UNI EN ISO 14001.



Un'impresa
socialmente responsabile



A socially responsible company

To the scope of intensifying our commitment to society, Varvel since 2004 started an ongoing support programme with three non-profit institutions: UNICEF (United Nations Children's Fund), MSF (Médecins sans Frontières) and ANT (National Cancer Association). Environmental respect and protection are also part of Varvel's values and this is why Varvel certified in 2001 its Environmental System to standard UNI EN ISO 14001.

Ein Unternehmen mit sozialer Verantwortung

Im Rahmen der Intensivierung unseres gesellschaftlichen Engagements startete Varvel ein seit 2004 laufendes Unterstützungsprogramm von drei Hilfsorganisationen: UNICEF (United Nations Children's Fund), MSF (Ärzte ohne Grenzen) und ANT (Nationale Krebs Gesellschaft). Da Schutz der Umwelt ebenfalls Teil der von Varvel geachteten Werte ist, erwarb Varvel seit 2001 die Zertifizierung UNI EN ISO 14001 für seine Anlagen.



Altri cataloghi
Other catalogues
Andere Kataloge

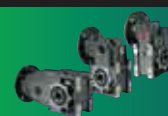

RN/RO/RV



RD



RS/RT



RG



VR/VS

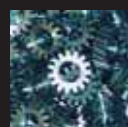

VARVEL®
MOTION CONTROL SINCE 1955



Bearings &
Power Transmission Pty Ltd
Phone 07 4636 0522

Bearings & Power Transmission Pty Ltd
(Phone) 07 4636 0522
Email: sales@bpt.net.au
(website) www.bpt.net.au

IT
GB
DE