

Sprocket Idlers

These sprocket idlers are designed for agricultural detachable link chain. They are installed with standard 1/2 or 5/8 bolts, and include accurately contoured hardened teeth to resist wear and damage to the chain. BPT idlers are compact and easy to install and built for a long maintenance-free service life.

ADVANTAGES

- Case hardened teeth prolong chain and idler life. Accurately contoured teeth from heavy gauge steel
- Over-size, factory packed lubricant chamber assures maximum life and operating efficiency without troublesome relubrication
- Bearing races are hardened to resist wear, outers and inners are accurately formed for smooth running
- BPT's self-contouring, free running, self-wiping seal provides positive contact under all conditions of misalignment
- Full ball complement for high durability

Detachable Chain Idlers

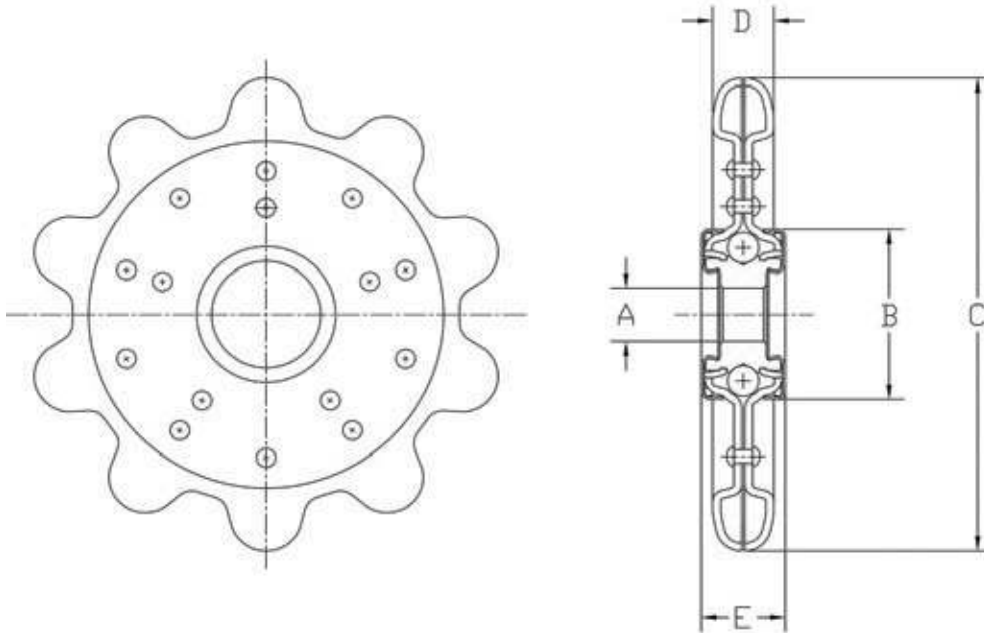

| PART NO. | UNIT | CHAIN NO | PITCH | ROLLER DIA | TEETH | A | B | C | D | E | WEIGHT (LBS / kg) |
|-------------|------|----------|-------|---------------|-------|---------------|---------|---------|-------|--------|-------------------|
| AG2422 | Inch | 62,62H | 1.654 | .670 / .686 | 7 | .643/.649 | 1-13/32 | 4-29/64 | 3/4 | 29/32 | 1.43 |
| | mm | | | 17.018/17.242 | | 16.332/16.484 | 35.718 | 113.109 | 19.05 | 23.018 | .6486 |
| AG2422-1AF* | Inch | 62,62H | 1.654 | .670 / .686 | 7 | .643/.649 | 1-13/32 | 4-29/64 | 3/4 | 29/32 | 1.43 |
| | mm | | | 17.018/17.242 | | 16.332/16.484 | 35.718 | 113.109 | 19.05 | 23.018 | .6486 |

**Includes Felt & Slinger Seals*