



BPT Gear Coupling follows the international standards of AGMA and JIS, which easily allows to replace with major industrial products. Our Gear coupling compensate angular misalignment, parallel misalignment and end float. The fully crowned hub teeth provide minimum loading stress, and ensure longer life.

1. Characteristic

1. High torque, small size, long life and very little loss of transmitting power.
2. The concave-convex flange design allows easy assembly and the high quality gasket prevent leakage of lubricant.
3. Gear Coupling permits parallel, angular misalignments and end floating by crown gear teeth.

☒ Parallel Misalignment

The driving and driven shafts are not parallel to each other, but not on the same straight line.

☒ Angular Misalignment

The driving and driven shafts installed with an limited angle.

☒ End Floating

The driving and driven shafts slide slightly along with the gear teeth.

☒ Composite Misalignment

Most of cases, above 3 misalignments appear with mixed in general use.

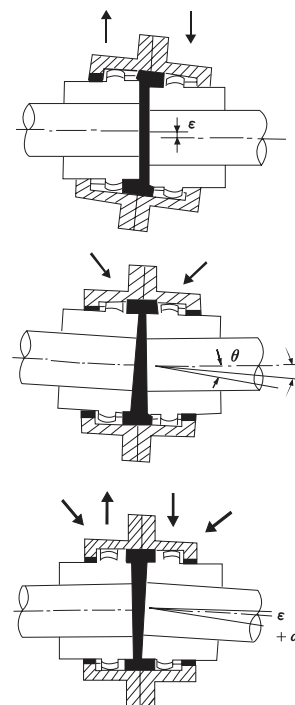

Allowable Misalignment

Size S	10G	15G	20G	25G	30G	35G	40G	45G	50G	55G	60G	70G	80G	90G	100G	110G	120G
ε(mm)	1.2	1.3	1.7	2.1	2.4	2.9	3.2	3.6	4.1	4.5	5.0	5.9	6.7	7.4	8.2	12.7	12.7
θ (α)	3(1.5)	3(1.5)	3(1.5)	3(1.5)	3(1.5)	3(1.5)	3(1.5)	3(1.5)	3(1.5)	3(1.5)		2(1)	2(1)	2(1)	2(1)	2(1)	2(1)

☒ Data subject to double engagement couplings.

- The coupling made of S45C has a good endurance to high speed and peak load.
Consult us for special materials, if required.
- Customer's requirements of special design can be acceptable.

2. Structure

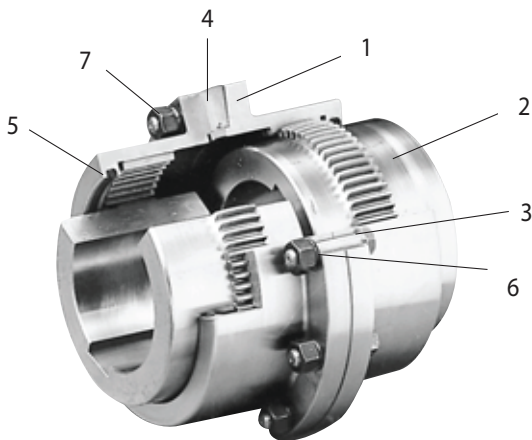

- Internal Gear(Flanged Sleeve)
- Crown Gear(Crown Gear Hub)
- Reamer Bolt or AGMA Bolt
- Gasket
- O-ring
- Spring Washer
- Hex. Bolt& Nut

☒ The crowned hub teeth provide larger contact area and decrease the stress.

3. Application

- Heavy load, but compact design coupling.
- High speed up to 5,000rpm(Depending on size, refer to the data)
- Low speed, but high starting torque.
- End float application.
- Spacer required, due to longer distance between shaft ends.
- Low load and light weight application is not recommendable.