

# MAX DYNAMIC<sup>®</sup> Coupling

## - Omega<sup>®</sup> equivalent

### Characteristics of MAX DYNAMIC<sup>®</sup> Coupling

1. Facility protection for twirl and twist, impact and abrasion
2. Very simple replacement and maintenance without oil and grease
3. Very simple replacement without the separation of motor or connector on the related line due to it's simple structure
4. Possible for the dissimilar connection and assembling with same hub
5. Polyurethane based for having good water resistance, chemical resistance
6. Highest flexible elasticity on run
7. Less noise



### Application

- Agitator
- Blower
- Compressor
- Conveyors
- Cranes and Hoists
- Elevators
- Fans
- Generators
- Pump
- Brewery and Distilling
- Food Industry
- Lumber Industry
- Pulp and Paper Mill
- Rubber Industry
- Steel Industry
- Textile Mills
- Aggregate Processing Cement

## MAX DYNAMIC<sup>®</sup> Standard Coupling

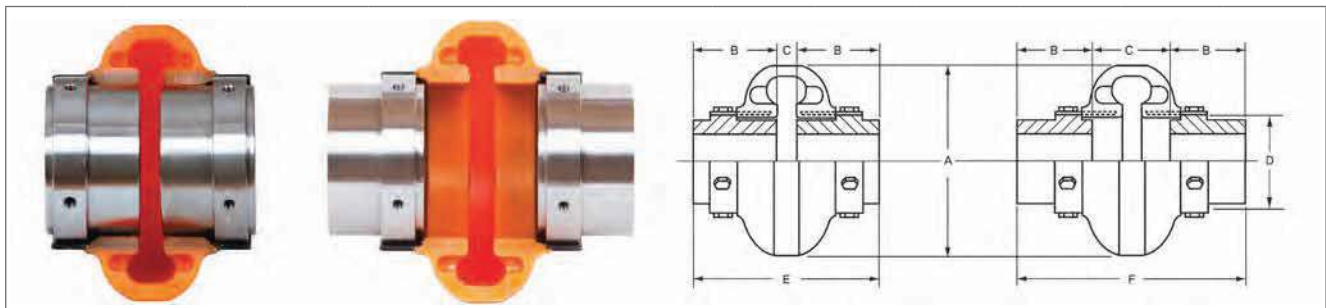

Max Dynamic Coupling No.	Torque (kgf.m)	Max. Bore (mm)	Max. rpm	Power Rating (kw/rpm)	Dimensions (mm)						
					A	B	C		D	E	F
					Out Dia	Hub Length	Min. Shaft Spacing	Max. Shaft Spacing	Hub Dia	Total Length	
								In		Out	
D-2	2.20	28	7,500	0.0023	89	24	35	47	47	83	95
D-3	4.20	34	7,500	0.0043	102	32	9	47	59	83	111
D-4	6.40	42	7,500	0.0066	116	37	9	47	66	83	121
D-5	11.00	48	7,500	0.0110	137	45	10	52	80	100	142
D-10	16.70	55	7,500	0.0170	162	45	11	53	93	101	143
D-20	26.70	60	6,600	0.0270	184	50	15	63	114	115	163
D-30	42.10	75	5,800	0.0430	210	56	12	68	138	124	180
D-40	63.40	85	5,000	0.0660	241	61	12	74	168	134	196
D-50	88.20	90	4,200	0.0900	279	69	12	86	207	150	224
D-60	144.00	105	3,800	0.1480	318	80	11	99	222	171	259
D-70	254.00	120	3,600	0.2620	356	85	18	109	235	189	281
D-80	455.00	155	2,000	0.4670	406	114	17	149	286	245	377
D-100	980.00	171	1,900	1.0000	533	140	44	95	359	324	375
D-120	1,961.00	190	1,800	2.0000	635	152	57	124	448	362	429