

# MAX DYNAMIC® Standard Coupling with Compression Bushed Hubs

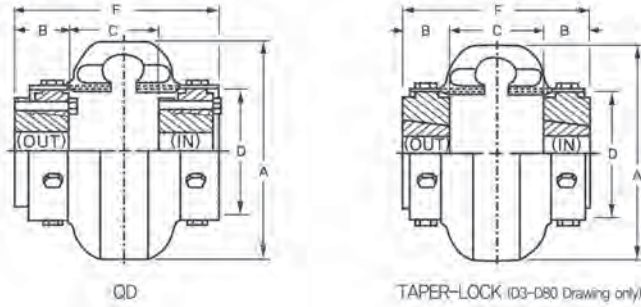

## Specification Data with Taper-Lock Hubs

Max Dynamic Coupling No.	Taper Lock Bush No.	Torque (kgf.m)	Max. Bore (mm)	Max. rpm	Power Rating (kw/rpm)	Dimensions (mm)						Weight (kg)	
						A	B	C	D	E	F		
						Out Dia	Hub Length	In	Hub Dia	Total Length			
D-3	1008	4.2	25	7,500	0.0043	102	22	43.0	59	87		0.82	
D-4	1008	6.4	25	7,500	0.0066	116	22	43.0	66	87		1.18	
D-5	1108	11.0	28	7,500	0.0110	137	22	56.0	80	100		1.81	
D-10	1610	16.7	35	7,500	0.0170	162	25	52.0	93	103		2.72	
D-20	1610	26.7	42	6,600	0.0270	184	25	63.5	114	114		4.08	
D-30	2012	42.1	50	5,800	0.0430	210	32	65.0	138	129		6.17	
D-40	2517	63.4	65	5,000	0.0660	241	44	60.0	168	149		9.89	
D-50	2517	88.2	65	4,200	0.0900	279	44	76.0	207	165		14.29	
D-60	3020	144.0	75	3,800	0.1480	318	51	84.0	222	186		21.14	
D-70	3535	254.0	100	3,600	0.2620	356	89	60.0	235	238		30.25	
D-80	4040	455.0	100	2,000	0.4670	406	102	95.0	286	298		37.19	
								In	Out		In	Out	
D-100	4545	980.0	110	1,900	1.0000	533	114	38	152	359	267	381	113.40
D-120	5050	1,961.0	125	1,800	2.0000	635	127	51	181	448	305	435	185.07